

L:

CBL-RTPD3SABB-1m	1000mm±10mm
CBL-RTPD3SABB-2m	2000mm±20mm
CBL-RTPD3SABB-3m	3000mm±20mm
CBL-RTPD3SABB-4m	4000mm±30mm
CBL-RTPD3SABB-5m	5000mm±30mm

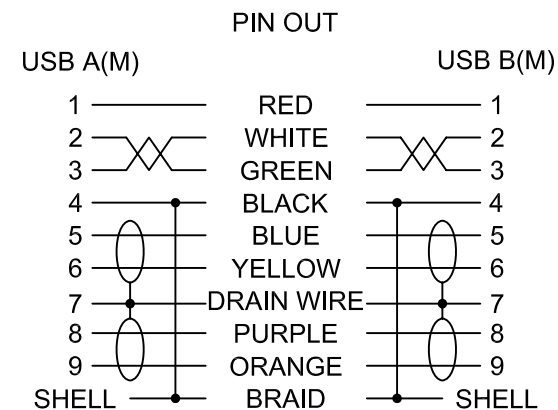

No	MATERIALS LIST:
1.	CABLE: 3 x (2 x 26 AWG)ST + 2 x 24 AWG O.D.:8.0mm COLOR:BLACK
2.	CONNECTOR:USB 3.0 A/M, 9P, BLUE INSULATOR SOLDER TYPE, NICKEL PLATED SHELL
3.	CONNECTOR:USB 3.0 B/M, 9P, BLUE INSULATOR SOLDER TYPE, NICKEL PLATED SHELL
4.	PVC MOLDED HOUSING, BLACK COLOR
5.	ABS ASSEMBLY HOUSING, BLACK COLOR

Jargy part no.	Client part no.	Approved	SCALE	UNIT
CBL-RTPD3SABB-xm				mm
Drawing Name		Drawn	Date	REV.
USB 3.0 A to B Cable M/M				1.0

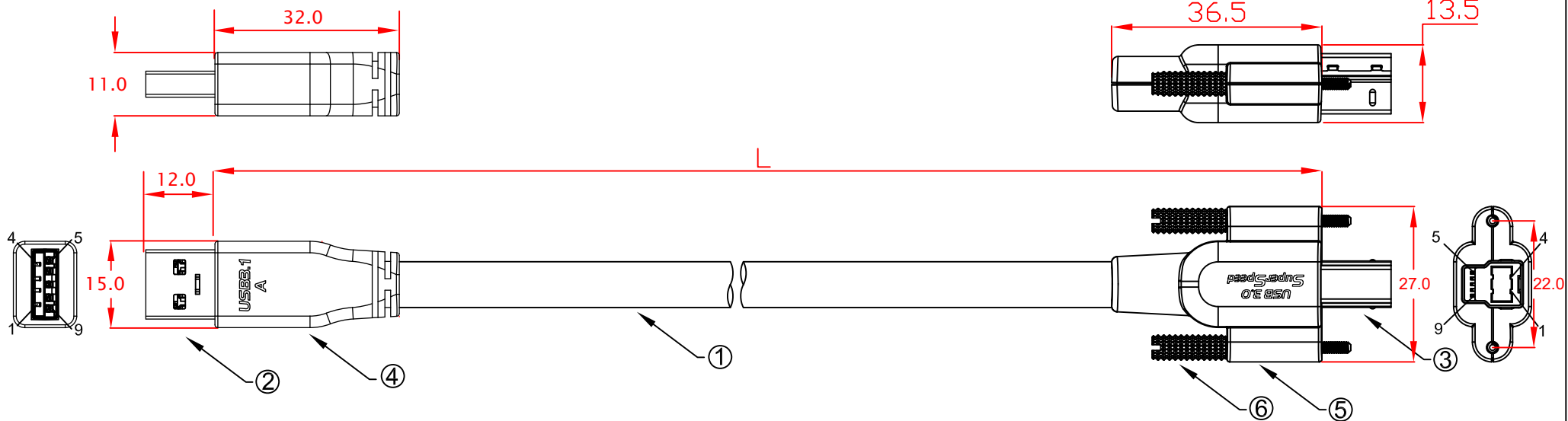

L:

CBL-RTPD3SABBS-1m	1000mm±10mm
CBL-RTPD3SABBS-2m	2000mm±20mm
CBL-RTPD3SABBS-3m	3000mm±20mm
CBL-RTPD3SABBS-4m	4000mm±30mm
CBL-RTPD3SABBS-5m	5000mm±30mm

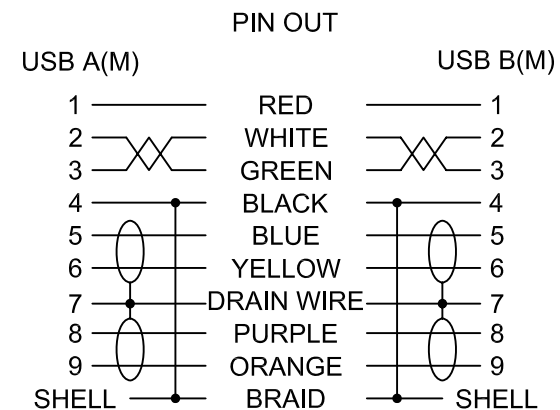

No	MATERIALS LIST:
1.	CABLE: 3 x (2 x 26 AWG)ST + 2 x 24 AWG O.D.:8.0mm COLOR:BLACK
2.	CONNECTOR:USB 3.0 A/M, 9P, BLUE INSULATOR SOLDER TYPE, NICKEL PLATED SHELL
3.	CONNECTOR:USB 3.0 B/M, 9P, BLUE INSULATOR SOLDER TYPE, NICKEL PLATED SHELL
4.	PVC MOLDED HOUSING, BLACK COLOR
5.	ABS ASSEMBLY HOUSING, BLACK COLOR
6.	SCREW:#4x34.5 M2

Jargy part no.	Client part no.	Approved	SCALE	UNIT
CBL-RTPD3SABBS-xm				mm
Drawing Name		Drawn	Date	REV.
USB 3.0 A to B Cable M/M				1.0

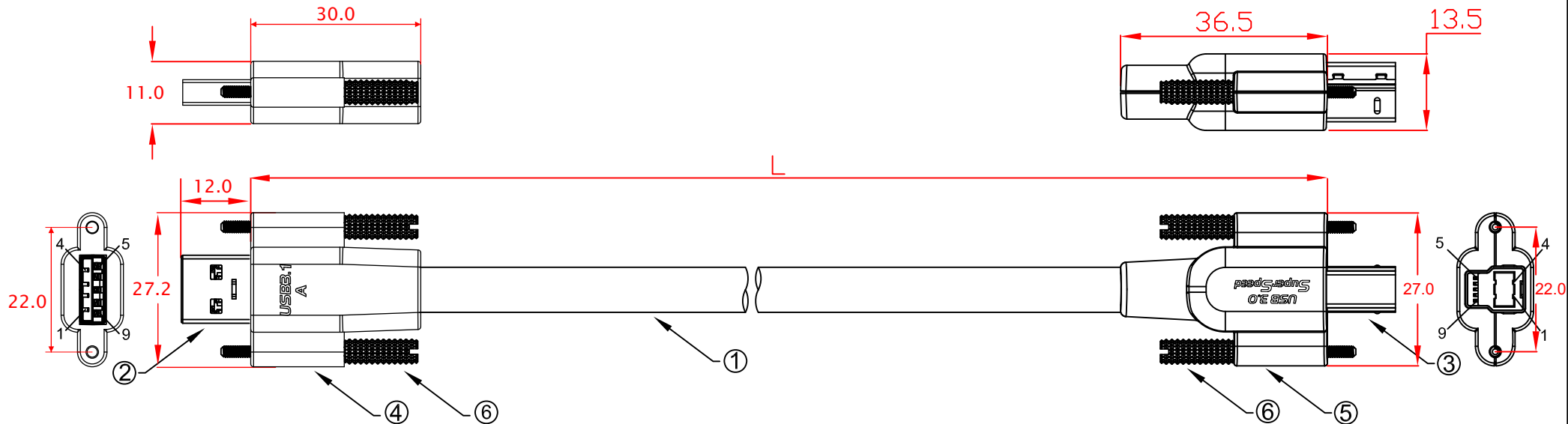

- L:
- CBL-RTPD3SABBSS-1m 1000mm±10mm
 - CBL-RTPD3SABBSS-2m 2000mm±20mm
 - CBL-RTPD3SABBSS-3m 3000mm±20mm
 - CBL-RTPD3SABBSS-4m 4000mm±30mm
 - CBL-RTPD3SABBSS-5m 5000mm±30mm

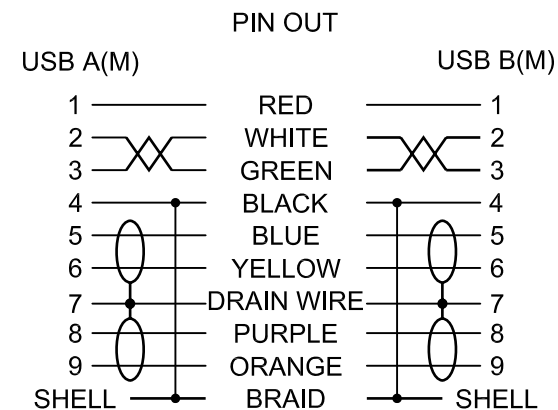

No	MATERIALS LIST:
1.	CABLE: 3 x (2 x 26 AWG)ST + 2 x 24 AWG O.D.:8.0mm COLOR:BLACK
2.	CONNECTOR:USB 3.0 A/M, 9P, BLUE INSULATOR SOLDER TYPE, NICKEL PLATED SHELL
3.	CONNECTOR:USB 3.0 B/M, 9P, BLUE INSULATOR SOLDER TYPE, NICKEL PLATED SHELL
4.	PVC MOLDED HOUSING, BLACK COLOR
5.	ABS ASSEMBLY HOUSING, BLACK COLOR
6.	SCREW:#4x34.5 M2

Jargy part no.	Client part no.	Approved	SCALE	UNIT
CBL-RTPD3SABBSS-xm				mm
Drawing Name		Drawn	Date	REV.
USB 3.0 A to B Cable M/M				1.0

